







Temporary Use of Public Property Program

As of September 20, 2011, The Town of Rocky Mountain House is now accepting applications for Temporary commercial uses of Public Property. Public Property can include use of Sidewalks, Road right of way, Parks, Parking lots, or other public spaces.

Temporary Uses allowed:

-  Sidewalk Sales
-  Patios
-  Buskers
-  Mobile Vendors
-  Abutting Vendors
-  For-Profit Events
-  Not-for Profit Events

The purpose is to create vibrancy and enhance existing commercial areas. An additional benefit is to allow space for small home occupations and young entrepreneurs to grow their businesses.



The Planning and Community Development Department will issue Temporary Business Licenses for Temporary Uses with a start and end date.

Application Requirements:

1. A sketch showing layout, location, and dimensions
2. Description of use, along with hours of operation
3. Photos and description of any equipment/structures (ex. vending cart)
4. Time period requested along with start and end date.
5. Name of business/use/event
6. A policy of liability insurance naming the Town of Rocky Mountain House as Additionally Named Insured.

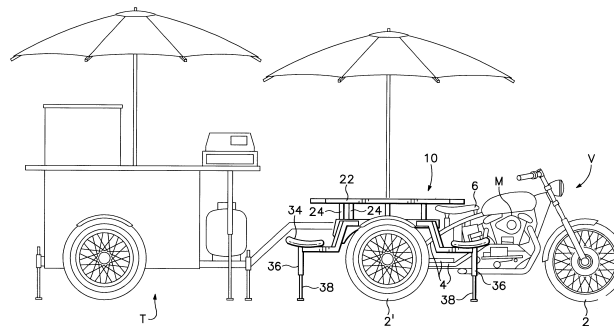

Application Fees:

Sidewalk Sales	Free!
Patios	\$150.00
Buskers	\$250.00 Annual (\$15.00/ day)
Mobile Vendors	\$360.00 Annual (\$25.00/day, minimum 7 days)*
Abutting Vendor	Free!
For-Profit Events	\$100.00/ Event
Not-for Profit Events	Free!

*Mobile Vendors are not subject to a minimum 7 days payment if partaking in a For-profit or not-for profit event, but is still subject to a \$25.00/day fee.



Use Specific Regulations:

Sidewalk Sales

- ✚ Tables, racks and chairs should be of uniform style and may not be anchored to the sidewalk or road.
- ✚ Only allowed abutting the frontage of an existing commercial establishment
- ✚ Non perishable items only.



Mobile and Abutting Vendors



- ✚ Vendors required to recycle glass, cans, and plastics in separate containers
- ✚ Vendor must collect and dispose of any refuse within a 6-meter area of stand.
- ✚ The Town of Rocky Mountain House reserves the right to relocate the Vendor
- ✚ All vending must be oriented toward the sidewalk traffic
- ✚ A vendor that is consistently moving from designated sites in Town must provide a plan showing these sites along with approximate times.

Patios

- ✚ A building permit may be required if applicant wishes to construct a structure in License area.
- ✚ Patios are encouraged to have an open appearance with a defined edge.
- ✚ Must be adjacent to the frontage (either side of a double frontage lot) of an existing restaurant, café, or drinking establishment.
- ✚ Smoking is not allowed in the Patio area



For more information, please call the Planning and Community Development Department at 403-847-5260 or email bdollevoet@rockymtnhouse.com